

# PC 1200 series

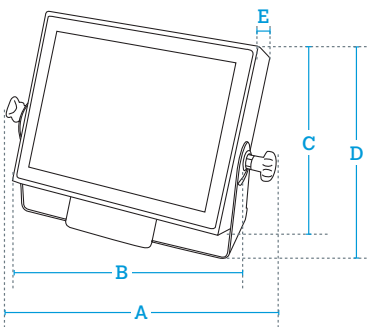

## DIMENSIONS



DATA IN mm

A	480
B	371
C	298 (without Wi-Fi)
D	388 (without Wi-Fi)
E	125

Weight with packaging:  
15-16 kg.



15"  
TOUCH SCREEN



PC  
ARCHITECTURE



WINDOWS 10



LINUX  
(CONSULT)



128 GB  
mSATA



USB

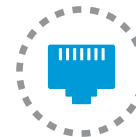

ETHERNET



WI-FI  
OPTIONAL



IP65/IP67  
PROTECTION

# Characteristics and functionality

## Main characteristics

---

- **High-resistance industrial PC, with touch screen, for integration with software applications and ERP systems.**

## Outstanding functions

---

- **Different software applications can be installed.**
- **The ERP can be integrated in the PC 1200 and work with the weighing application either in the same device or connected from an external PC.**
- **Microsoft Windows 10 embedded.**

## CPU

---

- **Processor:** Intel Celeron or Intel i3.
- **Memory:** 4 GB, DDR3.
- **Hard disk drive:** 128 GB mSATA.
- **Optional:**
  - Wi-Fi.

## Construction

---

- **Structure:**
  - AISI 304 stainless steel housing.
- **Screen:**
  - 15" TFT resistive touch screen.
- **Adjustable angle mount** for table or wall included.
- **IP65/IP67 protection.**

## Connections on panel

---

- 1 USB.

## Internal connections

---

- **Intel Celeron model:**
  - 1 COM.
  - 3 USB (3.0).
  - 1 Ethernet.
  - 1 audio.
  - 3 RS-232 (optional with patch cord).
  - 1 Display Port.

- **Intel i3 model:**

- 1 USB (2.0).
- 2 USB (3.0).
- 2 Ethernet.
- 1 HDMI.
- 1 VGA.
- 3 RS-232 (optional with patch cord).

## Software

---

- **Open solution** to install all types of software applications (ERPs, production control, warehouse management, etc.).

## Power supply

---

- **230/110 V direct.**

## Energy consumption

---

- **40 W (max.).**

## Other possible peripherals

---

- **Scanner barcode reader** (only needs wiring for communications).
- **TV.**
- **1 audio (I/O).**
- **Others:** keyboard, mouse, etc.

## Models

### PC 1200 CELERON

- Intel Celeron.
- Windows 10 embedded (for other Windows version, contact us).

Ref.:  
**7YBZAWGOIO\_ \_**

### PC 1200 i3

- Intel i3.
- Windows 10 embedded (for other Windows version, contact us).

Ref.:  
**7RBZAWGOIO\_ \_**

## Options

Option	Characteristics	Reference
Wi-Fi	Wireless communications.	Consult
SW1100 PC Windows software	Application for configuration, sales and weighing management and labels and receipts design (DLD).	7340SW1100

## Accessories



Ref: 493358A

### Column

Stand for the indicator.



Ref: PE18137

### PC keypad mount

Tray for computer keypad.



Ref: BC-745

### Barcode reader

Scanner. Serial port cable not included.



Ref: BC-668

### Wireless barcode reader

Scanner. Serial port cable not included.